

NADY™ AUDIO

OWNER'S MANUAL

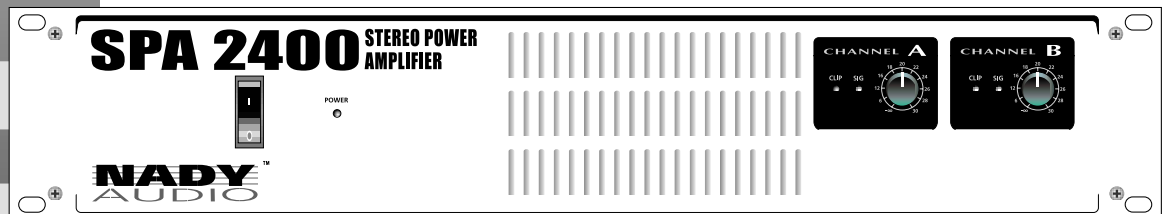
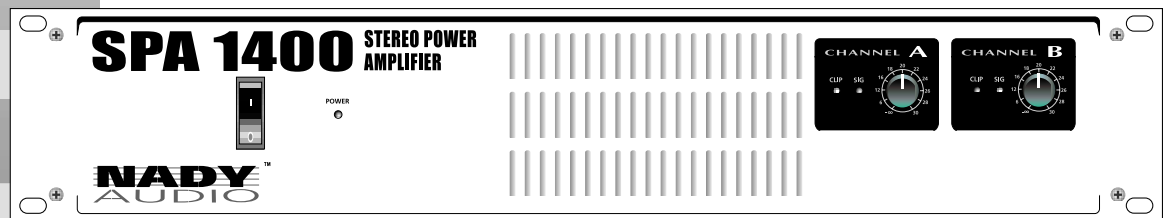
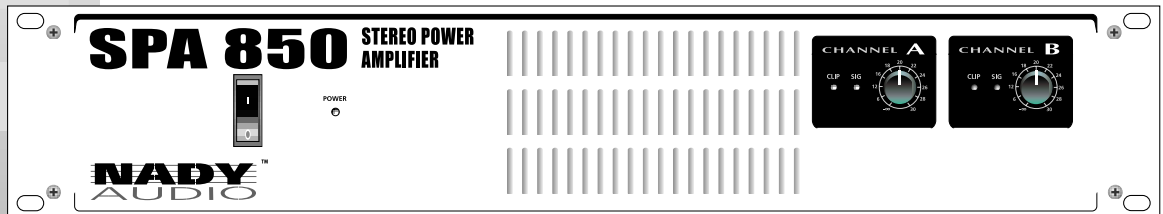

SPA Series Stereo Power Amplifiers

SPA SERIES

STEREO POWER AMPLIFIER



Congratulations on your choice of stereo power amplifiers — you have purchased one of the finest stereo amplifiers on the market today. This unit was developed using the expertise of professional sound engineers and working musicians. You will find that your new NADY AUDIO SPA 850/1400/2400 has superior performance and greater flexibility than any other amplifiers in its price range. Please read this manual carefully to get the most out of your new unit.

Thanks for selecting NADY AUDIO as your choice in amplifiers.

FEATURES

Offering top power, superior performance and full professional operating features in a roadworthy compact chassis, the SPA Series are perfect for even the most demanding sound reinforcement installation and touring applications.

The operating instruction in this manual are for the SPA 850, SPA 1400 and SPA 2400 power amplifiers. The operation and functions of these units are the same, except as noted.

- Continuously variable speed fan with back-to-front air flow
- Full operating features: user-defeatable clip limiter; switchable 30Hz low-cut filter; balanced XLR and 1/4" TRS inputs; detent volume controls; stereo (dual-channel, parallel-input, or bridged mono operating models with selector switch; binding post and Neutrik Speakon™ outputs; ground-lift switch
- Complete, advanced safety/reliability features: soft-start turn on; noise-free on-off; built-in DC offset; independent DC and thermal overload protection on each channel; short circuit and speaker protection; DC servo operation; built-in current limiter
- Parallel outputs allow "daisy chaining" amps
- ~115V (60Hz)/~230V (50Hz) AC select switch
- Clip and Signal LED indicators for each channel
- Durable double rack space (2U) steel casing
- **SPA 850** — 2 x 350W @4Ω, 2 x 425W @2Ω
Bridge mono: 600W @ 8Ω, 850W @ 4Ω
- **SPA 1400** — 2 x 500W @4Ω, 2 x 800W @2Ω
Bridge mono: 1000W @ 8Ω, 1400W @ 4Ω
- **SPA 2400** — 2 x 750W @4Ω, 2 x 1400W @2Ω
Bridge mono: 1600W @ 8Ω, 2400W @ 4Ω

CONTENTS

FEATURES	3
WARNING	4
FRONT AND REAR CONTROLS	5
INSTALLATION	7
CONNECTIONS	8
BLOCK DIAGRAM	10
SPECIFICATIONS	11

Date of Purchase _____

Dealer's Name _____

City _____

State _____ Zip _____

Model # _____

Serial # _____

WARNING

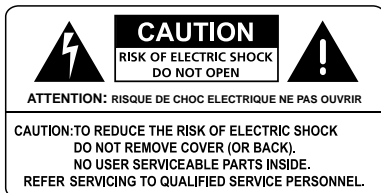

An equilateral triangle enclosing a lightning flash/arrowhead symbol is intended to alert the user to the presence of uninsulated "dangerous voltage" within the product's enclosure which may be of sufficient magnitude to constitute a risk of electric shock.



An equilateral triangle enclosing an exclamation point is intended to alert the user to the presence of important operating and service instructions in the literature enclosed with this unit.

IMPORTANT SAFETY INSTRUCTIONS

When using this electronic device, basic precautions should always be taken, including the following:

1. Read all instructions before using the product.
2. Do not use this product near water (e.g., near a bathtub, washbowl, kitchen sink, in a wet basement, or near a swimming pool, etc.).
3. This product should be used only with a cart or stand that will keep it level and stable and prevent wobbling.
4. This product, in combination with headphones or speakers, may be capable of producing sound levels that could cause permanent hearing loss. Do not operate for a long period of time at a high volume level or at a level that is uncomfortable. If you experience any hearing loss or ringing in the ears, you should consult an audiologist.
5. The product should be positioned so that proper ventilation is maintained.
6. The product should be located away from heat sources such as radiators, heat vents, or other devices (including amplifiers) that produce heat.
7. The product should be connected to a power supply only of the type described in the operating instructions or as marked on the product. Replace the fuse only with one of the specified type, size, and correct rating.
8. The power supply cord should: (1) be undamaged, (2) never share an outlet or extension cord with other devices so that the outlet's or extension cord's power rating is exceeded, and (3) never be left plugged into the outlet when not being used for a long period of time.
9. Care should be taken so that objects do not fall into, and liquids are not spilled through, the enclosure's openings.
10. The product should be serviced by qualified service personnel if:
 - A. The power supply cord or the plug has been damaged.
 - B. Objects have fallen into, or liquid has been spilled onto the product.
 - C. The product has been exposed to rain.
 - D. The product does not appear to operate normally or exhibits a marked change in performance.
 - E. The product has been dropped, or the enclosure damaged.
11. Do not attempt to service the product beyond what is described in the user maintenance instructions. All other servicing should be referred to qualified service personnel.

FRONT AND REAR CONTROLS

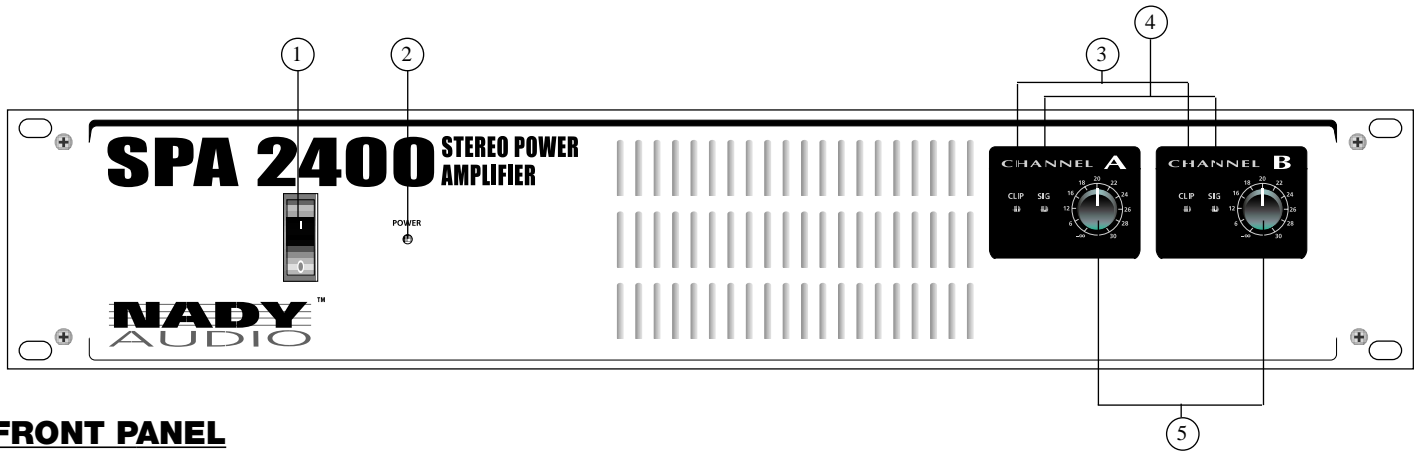

FRONT PANEL

1. POWER SWITCH

To turn the unit ON or OFF, press the upper or lower portion of this button. Before turning on the amplifier, check all connections and turn down the level controls. A momentary muting is normal when turning the amplifier on or off.

(Caution: Always turn on your power amplifier last, after all your other connected equipment, and always turn off your power amplifier before your other connected equipment.)

2. POWER LED INDICATOR

This LED illuminates when the power is turned “ON”.

3. CLIP (PEAK) LED INDICATORS

These LEDs illuminate if any section of the power

amplifier’s output are within 3DB of clipping. Occasional blinking of the LEDs are acceptable, but if they remain on more than intermittently you should turn down either the power amplifier’s level controls or reduce the output level of the preceding component to avoid audible distortion.

4. SIGNAL LED INDICATORS

These LEDs illuminate to confirm the presence of an input signal greater than 100 mV at that channel of the amplifier

5. LEVEL CONTROLS

These control the level of signal coming into each channel. The actual voltage gain of the amplifier is shown in dB. Turn these controls counterclockwise if the peak LEDs illuminate steadily (indicating too strong an input signal).

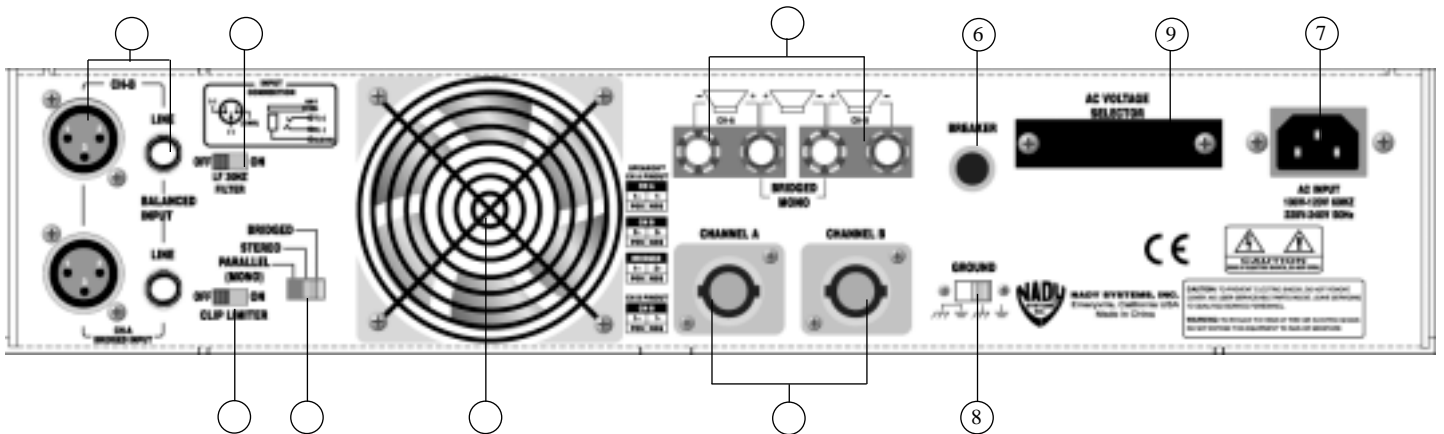

REAR PANEL

6. CIRCUIT BREAKER

A bimetallic circuit breaker is provided for protection of the amplifier. Press to reset if it trips. If it continuously trips upon resetting, refer servicing to qualified personnel.

7. POWER CONNECTOR

The cord connector is used to connect the AC power source to your power amplifier.

(CAUTION: DO NOT REMOVE THE CENTER GROUNDING PIN.)

8. GROUND LIFT SWITCH:

Switch to right to disconnect the chassis from ground if necessary to eliminate hum caused by ground loops.

9. AC VOLTAGE SELECTOR SWITCH:

Before plugging in the power cord, check to see that the unit is set for the proper voltage for your area: ~115V (60Hz) or ~230V (50Hz). A cover plate is provided to ensure that this switch is not accidentally reset or tampered with between uses.

10. L/R CHANNEL OUTPUT CONNECTORS (Speakon™ & Binding Posts)

The Speakon™ and binding post (banana jack) outputs are compatible with a speaker load of 2 Ω or greater (4Ω or greater for bridged operation). Connections are as depicted on the rear panel and in the following **CONNECTIONS** section on page 8 of this manual.

11. BALANCED INPUT CONNECTORS

(1/4" TRS & XLR)

These 1/4" (6.3mm) TRS (Tip/Ring/Sleeve) phone jacks and XLR jacks are compatible with balanced inputs and are wired as Tip/Pin 3 = (+), Ring/Pin 2 = (-), and Sleeve/Pin 1 = Ground. Normal maximum input level at clipping is 1.15V RMS (+ 4dB). Input impedance is 10K Ohms. Since the TRS phone jacks and XLR jacks are wired internally in parallel, you can parallel this unit with another amplifier by using either the LINE 1/4" jack or the XLR jack (depending on which you're using to input your signal) to output the signal to the input jack of the other amplifier.

The 1/4" TRS phone jacks can also be used for unbalanced inputs. For TRS phone plugs, simply connect the unused side of the balanced input to ground. For 1/4" TS phone plugs, no change is necessary for compatibility with this input. Balanced input signals are recommended as they are less prone to AC hum. For long cable runs a source of less than 600 ohms output impedance is needed to avoid signal loss. For short cable runs an unbalanced signal input should be suitable.

For stereo (two-channel) operation, use the inputs for both CH-A and CH-B; for parallel or bridged mono operation, use only CH-A input. (See 13-MODE SELECTOR SWITCHES below for more explanation.)

12. CLIP LIMITER SWITCH

This switches the internal Clip Limiter ON or OFF for both channels. The limiter prevents excessive signals from overloading the amplifier (and thus flattening the peaks of the waveform and introducing distortion) by automatically lowering the amplifier gain to minimize overdrive. This limiting is primarily used to protect full-range speakers from high frequency distortion or damage to the horns caused by bass overdrive. However, when driving a subwoofer, defeating the limiter can produce a desired extra "punch" to bass instruments, such as kick drums.

13. MODE SELECTOR SWITCH

The SPA Series amplifiers offer 3 modes of operation: PARALLEL, STEREO & BRIDGED. Slide the switch to one of the three positions for your application.

- **PARALLEL (MONO) INPUT** — This mode allows both channels to operate in parallel with the same signal and without requiring a Y-cord. In this mode the inputs for both channels are internally connected, so that you only need to feed a signal into one of the channels. This still allows independent control of each channel. It also enables easy "daisy-chaining" with other amps by using the other set of input connectors.

(Note: Do not select this "Parallel" mode when feeding the amplifier 2 separate signals.)

(Note: Do not use both unbalanced and balanced cables in the same set-up as that can unbalance all the connections when daisy-chaining, resulting in hum.)

- **STEREO INPUT** — This is the most common mode generally used, and allows independent control of 2 separate signals such as stereo playback, main and monitor live mixes, and bi-amp operation (highs in one channel and lows in the other).

- **BRIDGED MONO** — This mode combines the power of both channels to drive a single speaker. In this mode the amp produces 4 times the peak power and 3 times the sustained power into a 4 or 8 ohm speaker than each channel can deliver separately in stereo or parallel mode.

(CAUTION: In this mode the amplifier can deliver high power into a speaker. Make sure that the speaker, connectors and wiring can handle this output. Note that for prolonged overdriven outputs into a 4 ohm speaker the breaker may trip, so care must be taken not to overload the amplifier in such operation.)

Connect the input signal to CH-A input for bridged mono operation.

14. LF FILTER (30HZ) SWITCH

The low frequency LF filter rolls off frequencies below 30Hz when this switch is turned to the ON position. This filter improves the audio by limiting unwanted inaudible low frequency speaker cone movement. Unless a preceding device, such as a mixer, already has such a 30Hz roll-off, this filter should generally be employed for optimum audio and to protect your speaker from excessive cone excursions beyond its rated limit at sub-audio frequencies. Generally this switch should only be left "OFF" if you are monitoring the whole signal for frequency content, such as for studio playback.

15. FAN

The fan speed is varied continuously automatically to maintain the proper internal operating temperature. Rear-to-front airflow keeps amps and racks cool.

INSTALLATION

Rack Mounting

The SPA Series amplifiers are designed for standard 19" rack mounting as well as "stack" mounting without a cabinet. Use 4 screws and washers for mounting to the front rack rails. It is also a good idea to support the amps also in the rear, especially for mobile use where the amps will be subjected to shocks.

Amplifier Cooling

Also pay close attention to the cooling requirements. Since the airflow is from the rear to the front, it is important to keep both the inlet in the rear and the output in the front clear of obstructions to enable efficient cooling airflow. Since the amp exhausts to the front it does not contribute to heat buildup in the rear of the rack. It is important, however, that the other devices used in the rack allow plenty of cool air in the rear to enable proper cooling of the amp. Never block the air vents in the sides and front of the amplifier if the load seen by amplifier is less than 4 ohms and the amplifier is being run at high output levels. For best results, in such high output power applications you should augment the amplifier's air flow with a rack cooling system.

Internal Fuse Protection

Each of the SPA Series amplifiers has backup internal fuse protection on each channel on the secondary output circuitry of the power transformer. In almost all cases of power overload the external back panel circuit breaker, which is wired in the primary power input circuit of the power transformer, will trip before the internal fuses blow. Nevertheless, these fuses are valuable in that they can sometimes isolate the problem to a single channel, allowing operation of the other channel. Also, because they require added effort to rectify, they increase the vigilance of the operator in correctly eliminating the cause of the overload problem before further use. These fuses are located inside the units and require removal of the top of the chassis.

CAUTION: Never open the unit when connected to AC power as you can be severely shocked resulting in serious injury or even death. Please wait at least 5 minutes after disconnecting the unit from AC power to let any internal capacitors discharge before opening.)

Replace the fuse with the same type, size and power rating as noted in the illustration for your SPA Series amp. If it continuously blows, stop replacing the fuse and refer servicing to qualified personnel.

Internal Fuses for SPA 850/1400

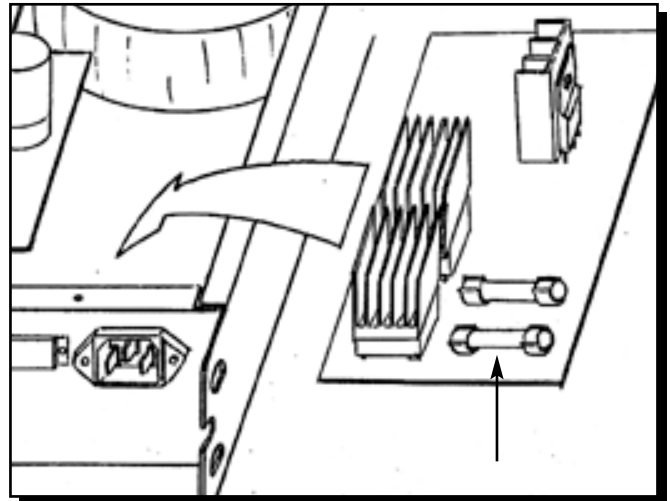

SPA 850 10A/250V (x2)
SPA 1400 12A/250V (x2)
both 3AG Fast Blow

Internal Fuses for SPA 2400

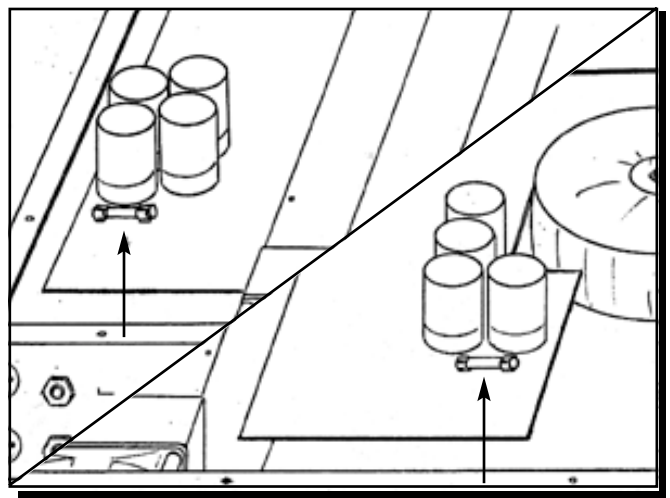

SPA 2400 25A/250V (x2)
both 3AG Fast Blow

CONNECTIONS

The following instructions describe the most common ways to install your amplifier into a sound system.

1. Turn off the amplifier power switch before making any connections.
2. The SPA Series amplifiers maybe operated in one of three modes (stereo, bridged-mono, and parallel mono). Refer to the following wiring diagrams for the speaker connections you wish to make.

(Note: Nady Systems assumes no liability for damaged speakers resulting from improper wiring, careless amplifier use, or over powering.)

Input Wiring Tips

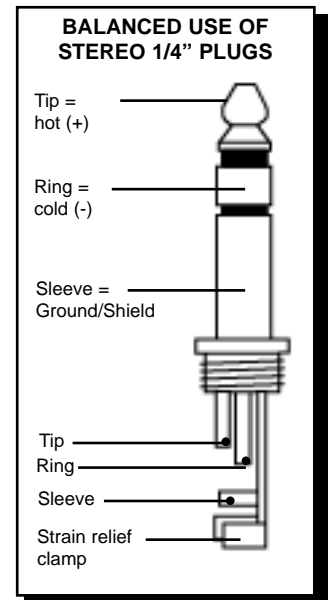
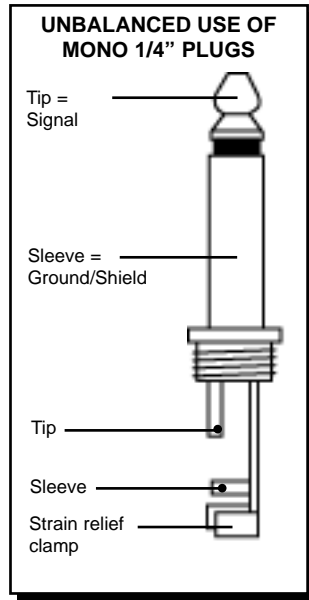
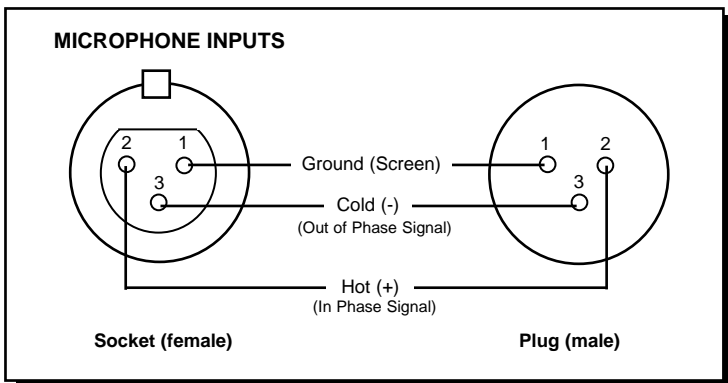

• Stereo (Two-Channel) Mode

To put the amplifier into stereo mode, first turn the amplifier off, then slide the **mode selector switch (13)** to the center "STEREO" position, and properly connect the input/output wiring as shown.

(Note: Do not connect a speaker load less than 2 ohms as it can damage your amplifier.)

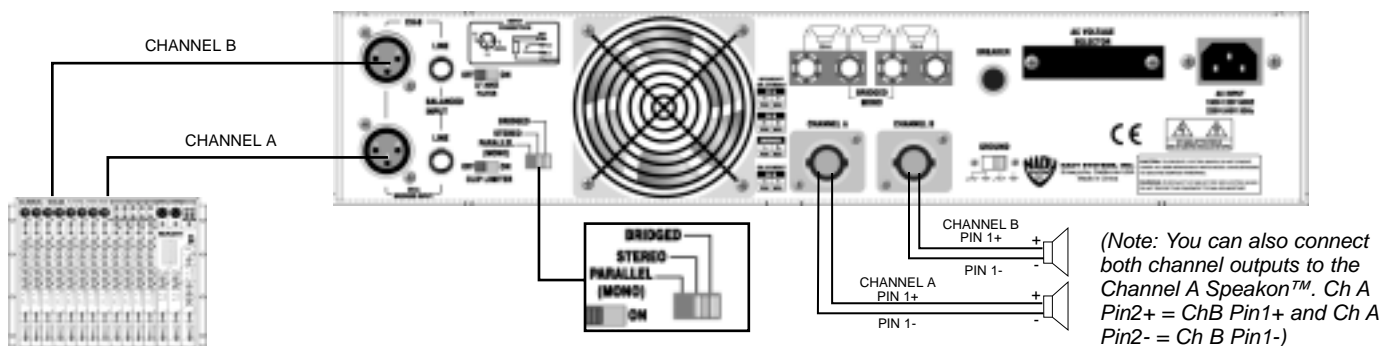

CONNECTIONS

• Parallel (Mono) Mode

To put the amplifier in parallel-mono mode, first turn the amplifier off, then slide the **mode selector switch (13)** to the left "PARALLEL (MONO)" position and properly connect the input/output wiring as shown. A signal into any input jack will drive both channels directly. You can patch the input signal on to any other amps using any of the remaining input jacks.

(Note: Do not connect a speaker load less than 2 ohms as it can damage your amplifier.)

[Note: Do not use the "PARALLEL (MONO)" switch when feeding the amp 2 separate signals.]

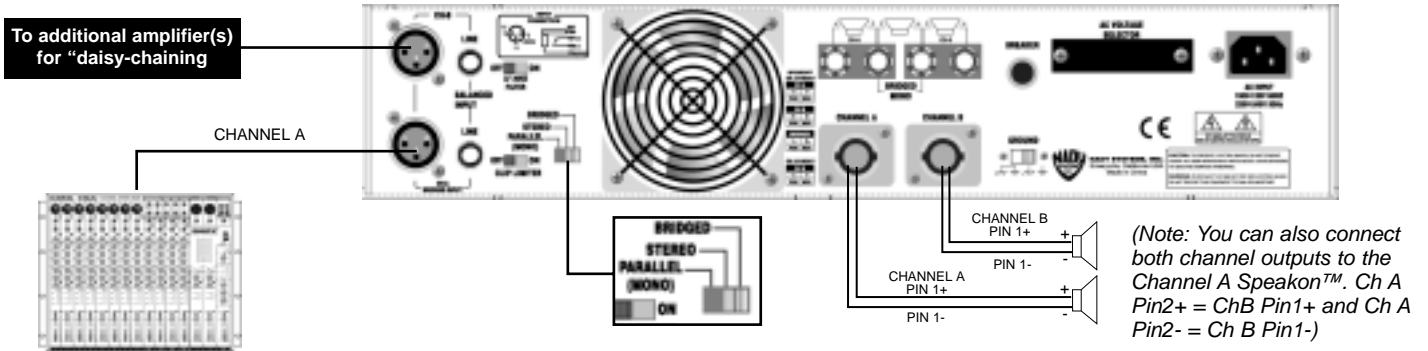

• Bridged Mono Mode

To put the amplifier in bridged mono mode, turn the amplifier off and slide the **mode selector switch (13)** toward the right "BRIDGED" position and properly connect the input/output wiring as shown. The signal is input into CH-A. Keep the level control of channel "B" turned completely down (counter clock wise).

(Note: Do not connect a speaker load of less than 4 ohms as it can damage your amplifier.)

(Note: This mode produces a large amount of power. Be sure that your wiring and speaker can handle it.)

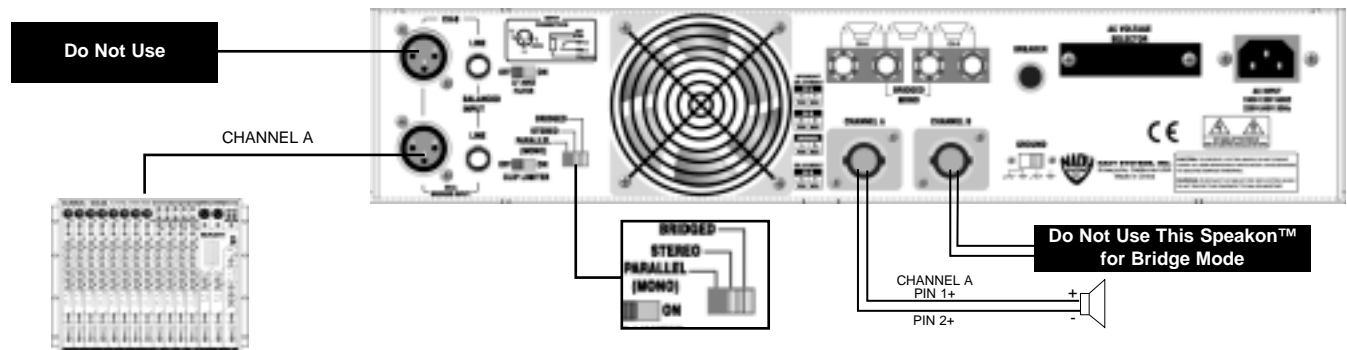

BLOCK DIAGRAM

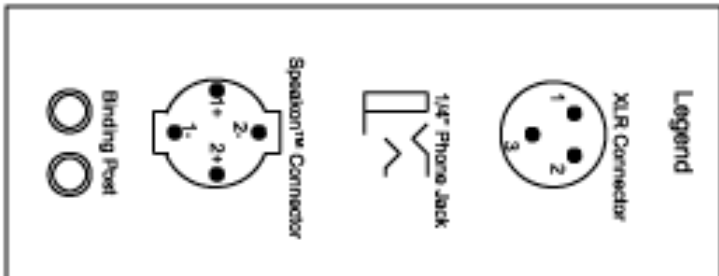
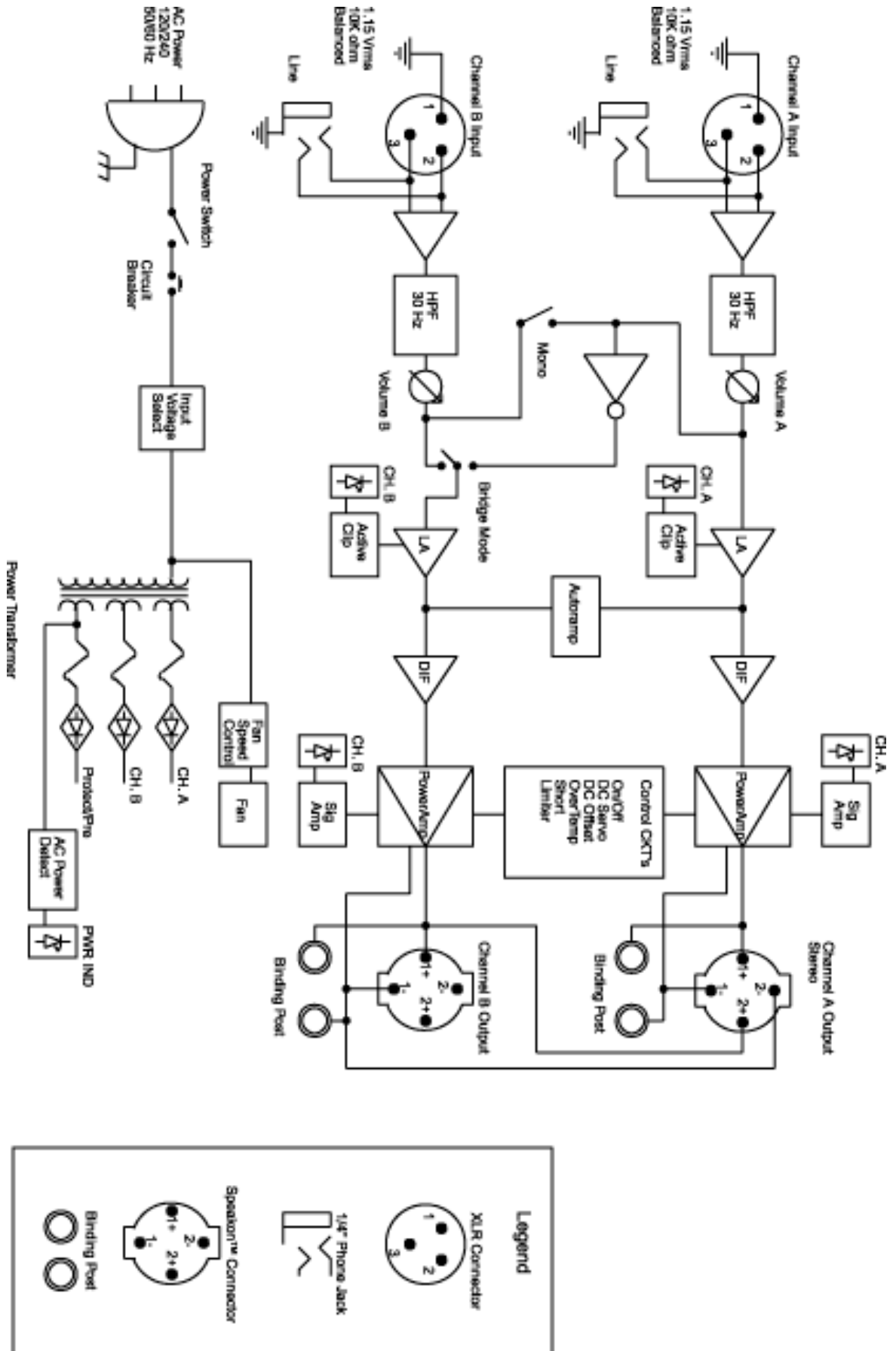

SPECIFICATIONS

POWER SPECIFICATIONS		SPA 850	SPA 1400	SPA 2400
	2Ω	425	800	1400
EIA out power	4Ω	350 + 350	500 + 500	750 + 750
1Hz, THD maximum 1%	8Ω	200 + 200	300 + 300	500 + 500
Both channels	Bridged 8Ω	600	1000	1600W
	4Ω	850	1400	2400

ELECTRICAL SPECIFICATIONS		SPA 850	SPA 1400	SPA 2400
INPUT SENSITIVITY		1.15V (+3.4dBu)	1.15V (+3.4dBu)	1.15V (+4dBu)
INPUT IMPEDANCE		10KΩ Unbalanced & Balanced		
FREQUENCY RESPONSE (at 10dB below rated output power)		25Hz~25KHz +0/-1dB -3dB points: 5Hz~50KHz		
VOLTAGE GAIN		30dB	32dB	34dB
DISTORTION (SMPTE-1M)		<0.03%	<0.03%	<0.03%
S/N ratio		100dB	100dB	100dB

GENERAL SPECIFICATIONS	SPA 850	SPA 1400	SPA 2400
PROTECTIONS	Full short circuit, open circuit, thermal, ultrasonic, and RF protection; stable into reactive or mismatched loads; ON/OFF muting; current limiter (crowbar)		
CONTROLS	Front: Power switch, 40 detent input level control for each channel. Rear: Parallel/Mono/Bridge selector, 30Hz filter selector, clip ON/OFF selector, ground lift switch, AC voltage selector switch, AC breaker		
INDICATORS	SIGNAL: 2 x green LED CLIP: 2 x red LED POWER: 1 green LED		
CONNECTORS	POWER: IEC power cord jack INPUT: Active balanced XLR and 1/4" (6.3mm) TRS OUTPUT: "Touch-proof" binding posts SPEAKON™ Connectors		
POWER SUPPLY	Voltage selectable: 110-120V or 220~240V AC 50/60Hz		
FUSES			
AC Primary — Rear Panel Breakers	11A	15A	20A
AC Secondary — Internal Fuses	10A/250V, 3AG, Fast Blow (x 2)	12A/250V, 3AG, Fast Blow (x 2)	25A/250V, 3AG, Fast Blow (x 2)
DIMENSIONS	19.0" x 15.7" x 3.5" (483 x 400 x 88.8mm)		
WEIGHT	29.9lb (13.6Kg)	34.3lb (15.6Kg)	41.8lb (19Kg)

The specifications above are correct at the time of printing of this manual. For improvement purposes, all specifications for this unit, including design and appearance, are subject to change without prior notice.

SERVICE FOR YOUR NADY AUDIO PRODUCT

(U.S.) Should your NADY AUDIO product require service, please contact the Nady Service Department via telephone at (510) 652-2411, or e-mail at service@nadywireless.com.

(International) For service, please contact the NADY AUDIO distributor in your country through the dealer from whom you purchased this product.

DO NOT ATTEMPT TO SERVICE THIS UNIT
YOURSELF AS IT CAN BE DANGEROUS
AND WILL ALSO VOID THE WARRANTY.

